

# 3341 A, 3344 A, 3348 A

## 6x6 All-wheel drive Specifications

# Actros

125! years of innovation



**Mercedes-Benz**  
Trucks you can trust

### Engine

Type	Mercedes-Benz OM 501 LA 11.9 litre turbocharged V6 408 - 476 hp (1,475 - 1,696 lb.ft) (See Actros Engines brochure for complete engine specification details)
------	--

### Transmission

Type	Mercedes-Benz G240-16/11.7-0.69 16 speed with Telligent® electronic control (3 pedal)
Transfer case	Mercedes-Benz, 2 gear On-road ratio 1.03 Off-road ratio 1.448

### Clutch

Type	Self-adjusting dual dry plate
Diameter	2 x 400 mm

### Axles

Front	Mercedes-Benz 7,500 kg capacity
Rear	Mercedes-Benz 2 x 13,000 kg capacity Planetary hub reduction 300 mm crown wheel Inter-axle and cross-axle differential locks
Ratio	4.833 - 1,730 rpm @ 100 km/h

### Suspension

Front axle	Mercedes-Benz 3 leaf parabolic springs Stabiliser bar and shock absorbers 9,000 kg capacity
Rear axle	Mercedes-Benz 6 rod with parabolic springs Stabiliser bar and shock absorbers 2 x 15,000 kg capacity

### Tank capacity

Diesel tank	400 litre rectangular aluminium tank on RHS
AdBlue tank	1 x 95 litre rectangular plastic tank on RHS

### Chassis

Main rail	289 mm web x 70 mm flange x 9.5 mm thickness High strength E 500 TM steel Steel bumper with swing steps
Exhaust system	SCR catalytic converter mounted on LHS with vertical outlet

### Brakes

Front/rear	Drum brakes 410 mm diameter Telligent® electro-pneumatic braking (EBS)
Service	10 bar operating pressure Automatic adjustment Air dryer ABS (anti-lock brakes) Roll back prevention
Trailer	2 line trailer brakes with hand control Air and electrical lines rear of frame
Engine brake	Active Engine Brake (AEB)

### Cab

Type	M (medium) cab ECE-R29 compliant cab (See Actros Cabins brochure for complete cab specification details)
------	--

### Steering

Type	Mercedes-Benz recirculating ball Integral power assistance Soft-feel 450 mm steering wheel Fully adjustable for height and rake
------	--

### Wheels and tyres

Wheels	10-stud 9.00 x 22.5 steel wheels
Tyres	Steer - 315/80 R 22.5 Drive - 315/80 R 22.5

### Electrical system

Voltage	24 volts
Batteries	2 x 12 V/220 Ah
Alternator	28 V/100 A
Starter	6.2 kW/24 V
Road lights	Halogen headlights
Fuses	Automatic fuses
Body Builder	Interface Module (PSM)

# Actros, 3341 A, 3344 A, 3348 A

## 6x6 All-wheel drive Specifications

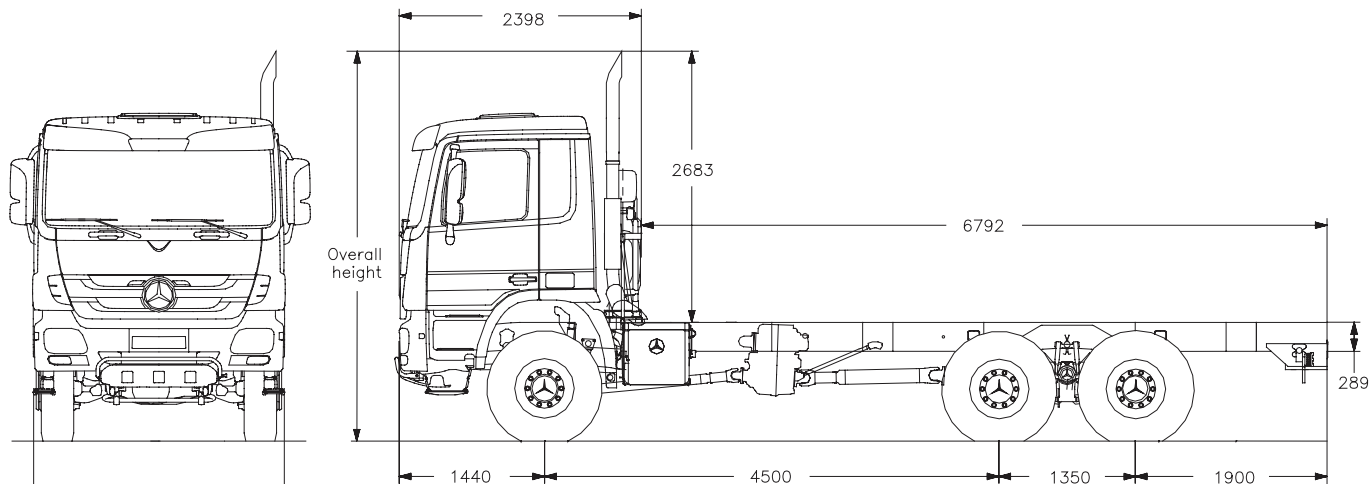

Note: drawings are general arrangement drawings only. Contact your authorised Dealer for details if required.

### Weights

Tare	
Front axle	5,663 kg
Rear axles	4,568 kg
Total	10,231 kg
Plated weights	
Front axle	7,500 kg
Rear axles	26,000 kg
GVM	33,000 kg
GCM	70,000 kg

Weights and dimensions shown are to specifications with no fuel, full AdBlue, oil, water and tools. Tare weights are subject to a manufacturing tolerance of  $\pm 3\%$ . MBAuP reserves the right to alter specification or equipment without notice.

### Dimensions

Air suspension	
Wheelbase	4,500 mm
Frame height at rear axle (unladen)	1,245 mm
Frame height at rear axle (laden)	1,155 mm
Overall height (unladen)	3,739 mm
Ground clearance front	344 mm
Ground clearance rear	327 mm
Cab tilt angle	70°
Turning circle (wall to wall)	20.3 m
Frame width at rear	760 mm

### Options

- Axle ratio 4.571
- Axle ratio 5.333
- Voith retarder
- Telligent<sup>®</sup> automatic gearshift (2 pedal)
- Short cab
- Long cab
- Wood trim dashboard
- Driver's and passenger's sunblind
- Chrome plated mirrors
- Front foglamps, halogen
- Painted grille
- Painted bumper
- PTOs
- Grammer, comfort, co-driver seat
- Centre seat with seatbelt
- Lower bunk
- 38 tonne GVM (includes 12.00 R 24<sup>+</sup> wheels and tyres)
- 40 tonne GVM (includes 12.00 R 24<sup>+</sup> wheels and tyres)

Authorised Dealer

To speak to your nearest authorised Mercedes-Benz Dealer call **1300 66 22 30**

**For full Warranty details and limitations contact your authorised Mercedes-Benz Truck Dealer.** IMPORTANT! This brochure has been compiled by Mercedes-Benz Australia/Pacific Pty Ltd to provide a general indication of the range of models available in Australia. Some of the models, features, optional extras and/or colours shown may not be available in Australia or may only be available in a different specification. Additionally, some models, features, optional extras and/or colours may only be available in combination with others. Some equipment depicted either on vehicle illustrations or separately may be non standard or options and may, where applicable, be available at an additional cost. For current information on the availability, design features and prices of all models, features, optional extras and/or colours available in Australia, you should contact your authorised Mercedes-Benz Truck Dealer on **1300 66 22 30** or go to [www.mercedes-benz.com.au/trucks](http://www.mercedes-benz.com.au/trucks). All of the information contained in this brochure was correct as at April 2011. However, the manufacturer reserves the right to discontinue, make changes to design and specifications to vehicles or optional equipment without notice. Mercedes-Benz Australia/Pacific Pty Ltd. ABN 23 004 411 410. Lexia Place, Mulgrave, Victoria 3170. Ph: (03) 9566 9266. Facsimile: (03) 9562 0397. The  and the words Mercedes-Benz, Telligent<sup>®</sup> and BlueTec<sup>®</sup> are registered trademarks of Daimler AG, Stuttgart, Germany.